

CALRACKS

3611 E. La Palma Ave Ste. B
Anaheim, CA 92806
800-244-3611

ASSEMBLY INSTRUCTIONS FOR: **INDUSTRIAL WORKBENCH**



ASSEMBLY OF INDUSTRIAL WORKBENCH WITH STEEL TOP

Tools Needed: A phillips-head screwdriver and a $\frac{7}{16}$ " wrench or nut driver.

Approximate assembly time for basic bench: 15 to 25 minutes.

1. Place the workbench top upside down on two sawhorses or a flat surface. Locate two mounting

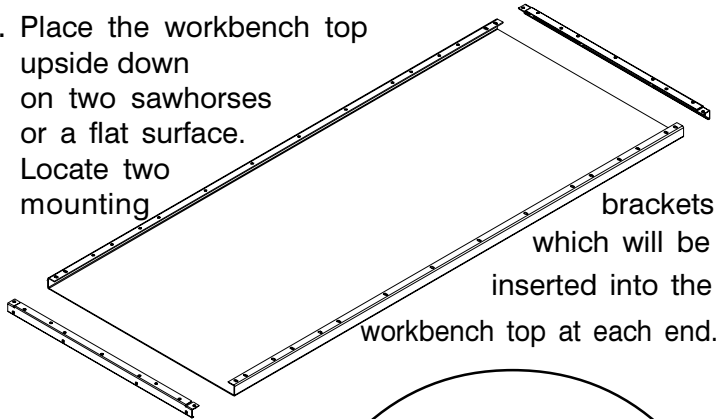

2. Insert a mounting bracket into one side of the top. Make sure that the side with the most holes is facing up, and that the open end is facing into the top. The holes in the top of the bracket ends will align with the last holes in the workbench top.

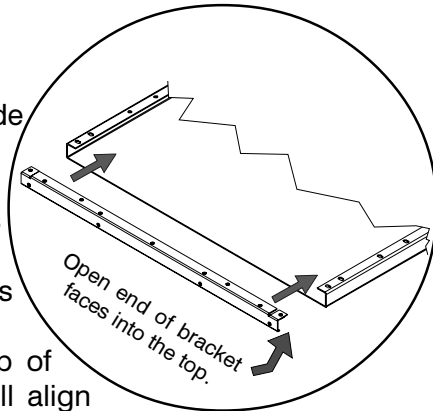

3. Place a workbench leg on the top, aligning the four end holes as shown below. Attach it by first threading two $\frac{1}{4}$ "-20 x $\frac{5}{8}$ " bolts through the leg, the top, and into the welded nuts on the mounting bracket. Then insert two more bolts through the leg and top, and secure with two $\frac{1}{4}$ "-20 nuts.

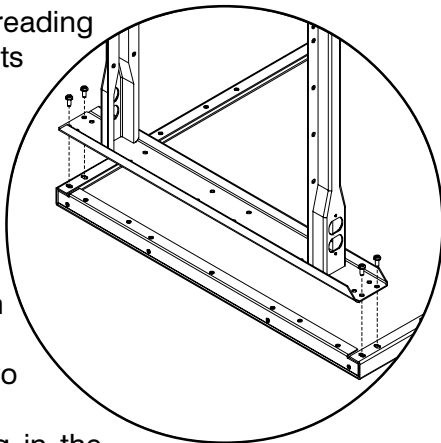

Attach the other leg in the same way.

NOTE: The drawings throughout this instruction sheet show the flared leg. If your bench came with adjustable legs, the legs will look different than the drawings shown throughout these instructions. The drawing shown here illustrates an example of both leg styles: the flared leg (shown at left) and the adjustable leg (shown at right).

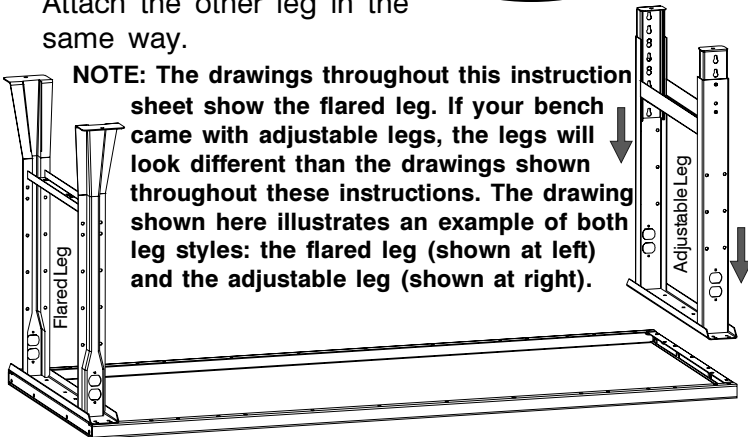

4. The two remaining mounting brackets are used either for additional desktop support, or to mount a workbench drawer. If you are adding the drawer to your bench, skip to step 5. Otherwise, attach the two remaining mounting brackets under the lip of the bench top for extra support, using one bolt on each end of each bracket. The brackets should be evenly spaced for maximum support.

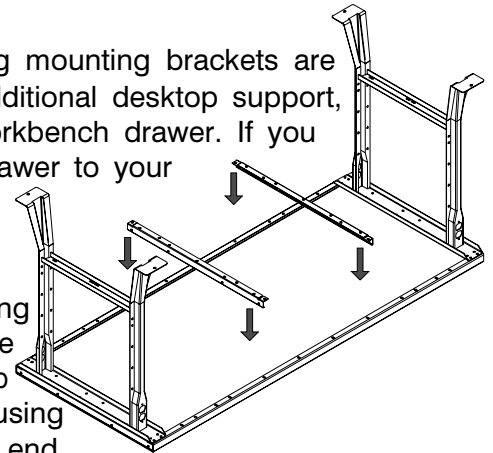

5. Attach the stringer to the rear legs, skipping the top two holes and using the next four holes from the top of each leg. (The legs are symmetrical, so the front and rear of the bench will be determined by where you place the stringer.) Attach with eight bolts, nuts, and lockwashers.

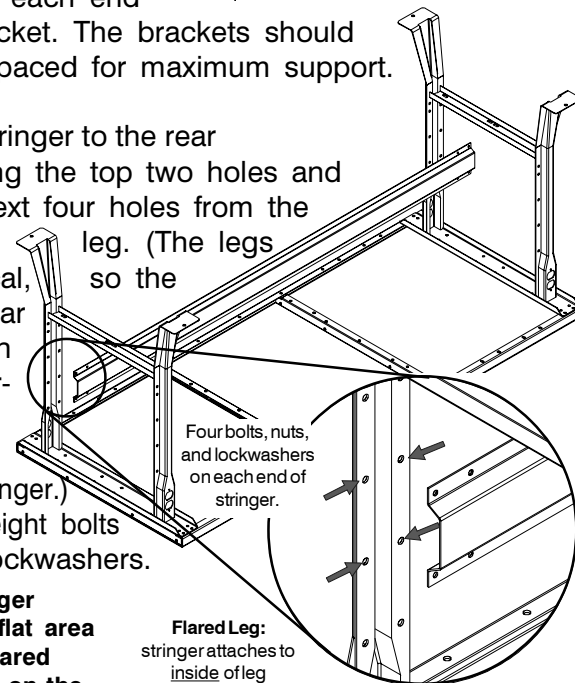

NOTE: The stringer attaches to the flat area of the leg. For flared legs, this will be on the inside of each leg; for adjustable legs, this will be on the outside of each leg (see the illustrations at right).

Flared Leg: stringer attaches to inside of leg

Adjustable Leg: stringer attaches to outside of leg

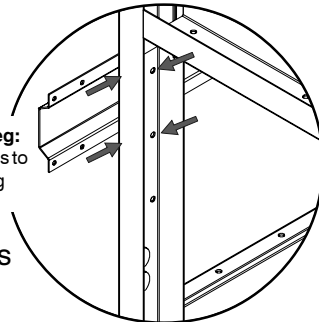

6. If you purchased only the basic workbench, your bench is now complete. The remaining instructions show assembly of optional accessories (such as the workbench drawer, the lower shelf, side and back rails, or risers).

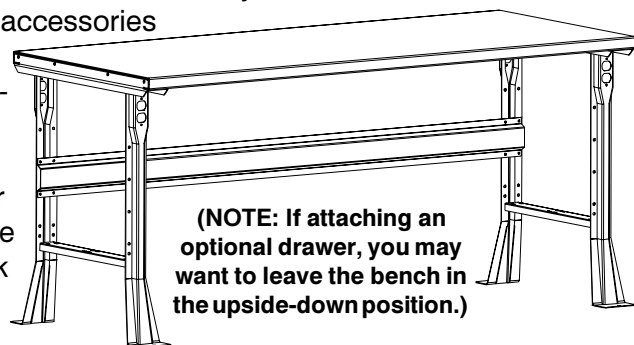

(NOTE: If attaching an optional drawer, you may want to leave the bench in the upside-down position.)

ASSEMBLY OF INDUSTRIAL WORKBENCH WITH WOOD OR PLASTIC TOP

Tools Needed: A phillips-head screwdriver and a $\frac{7}{16}$ " wrench or nut driver.

Approximate assembly time for basic bench: 15 to 25 minutes.

- Two different legs are available for Action's workbenches: the flared leg or the adjustable leg (see drawings below). Please note that your bench will have only one of these leg styles. For purposes of clarity, the remainder of this instruction sheet will show the flared leg only. However, both legs install with identical steps.

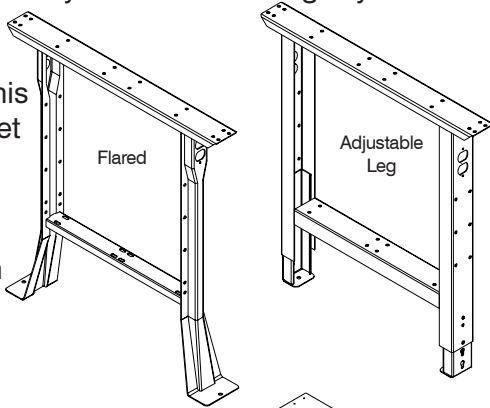

- Lay the top face down on two sawhorses or a protected flat surface.

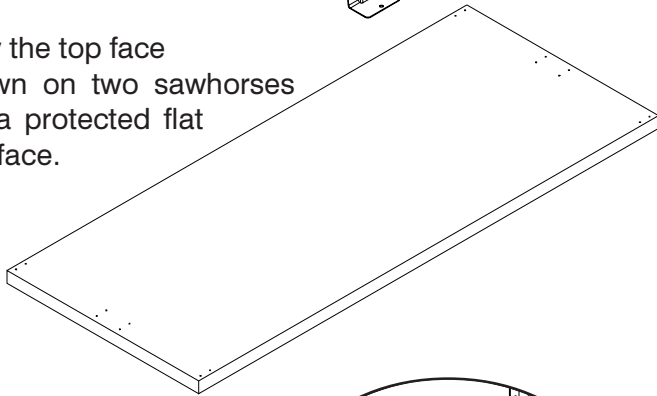

- Place a workbench leg on one end of the top, aligning with the eight pre-drilled pilot holes. Attach with eight #14 x $\frac{3}{4}$ " hex head slotted wood screws.

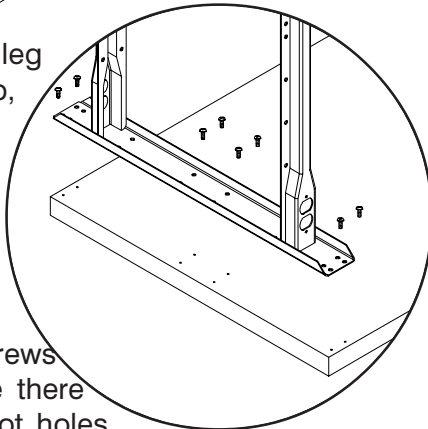

NOTE: No wood screws are necessary where there are no pre-drilled pilot holes.

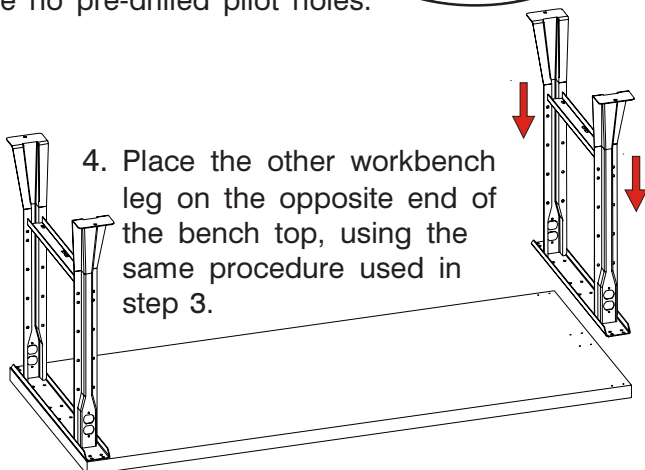

- Place the other workbench leg on the opposite end of the bench top, using the same procedure used in step 3.

- Attach the stringer to the rear legs, legs, skipping the top two holes and using the next four holes from the top of each leg. (The legs are symmetrical, so the front and rear of the bench will be determined by where you place the stringer.) Attach with eight $\frac{1}{4}$ "-20 x $\frac{5}{8}$ " bolts, nuts, and lockwashers.

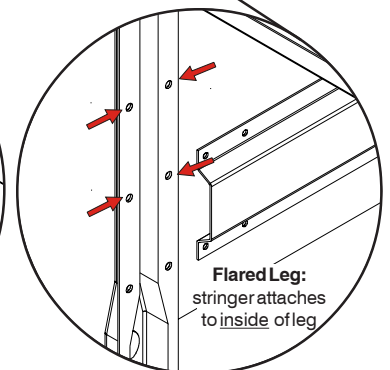
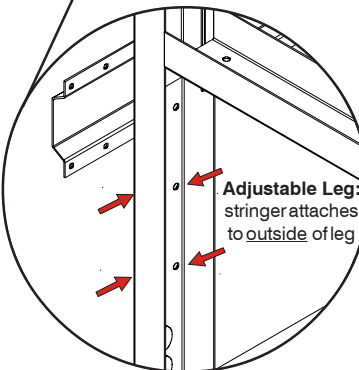
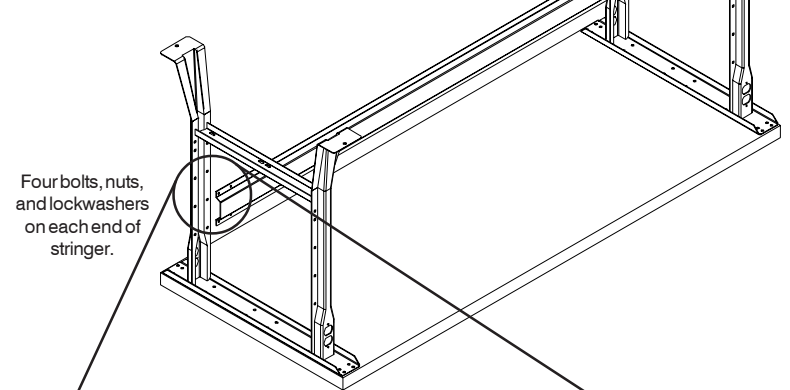

NOTE: The stringer attaches to the flat area of the leg. For flared legs, this will be on the inside of each leg; for adjustable legs, this will be on the outside of each leg (see the illustrations at right).

- If you purchased only the basic workbench, your bench is now complete. The remaining instructions show assembly of optional accessories (such as the workbench drawer, the lower shelf, or risers).

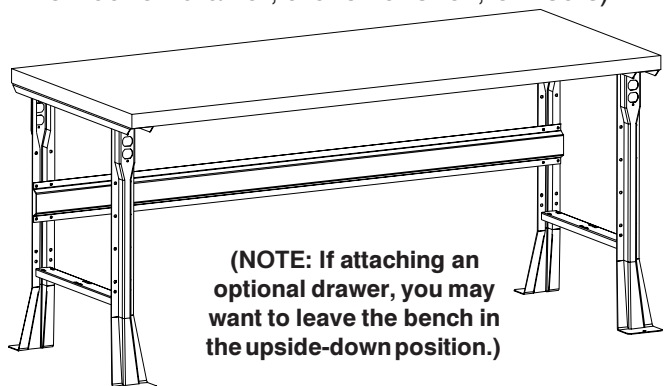

(NOTE: If attaching an optional drawer, you may want to leave the bench in the upside-down position.)

OPTIONAL ACCESSORIES

Optional Workbench Drawer

1. Remove the drawer from the drawer housing

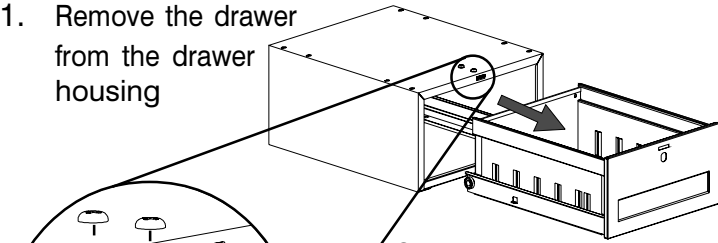

2. If using a padlock, place the lock hasp onto the two bolts which extend down from the drawer housing. Attach using two $\frac{1}{4}$ "-20 nuts. Remove the rectangular knock out panel on drawer front.

3. Attach the two remaining mounting brackets (referred to in step 4 on the previous page) in the desired location on the workbench top. It is most common to place the drawer to either the far left or far right side of the bench, but the drawer can be placed anywhere where there are two holes in the bench top that are 15" apart. Secure with two $\frac{1}{4}$ "-20 x $\frac{5}{8}$ " bolts per mounting bracket.

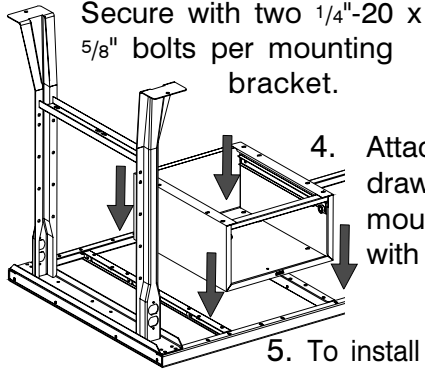
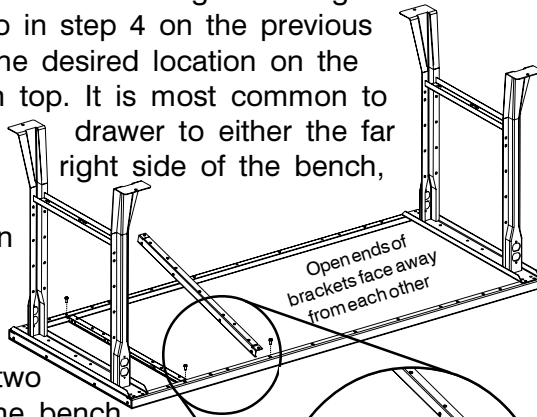

4. Attach the drawer housing to the mounting brackets. Secure with four $\frac{1}{4}$ "-20 x $\frac{5}{8}$ " bolts.

5. To install optional cam lock (Ref. No. 11), punch out the round knock-out panel in the drawer front. Then insert the cam lock through the hole, and secure with forked clip.

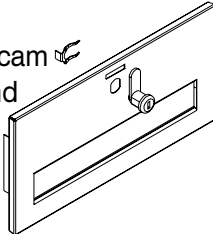

6. With the workbench upright, slide the drawer back into the drawer housing by tilting downward to let the drawer rollers move past each other.

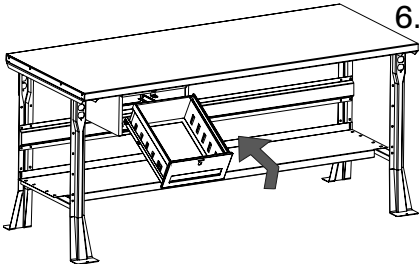

Optional Lower Shelf

1. Place the shelf (Ref. No. 12) on the brace of each leg. Attach with three $\frac{1}{4}$ "-20 x $\frac{5}{8}$ " bolts and nuts on each end of the shelf as shown.

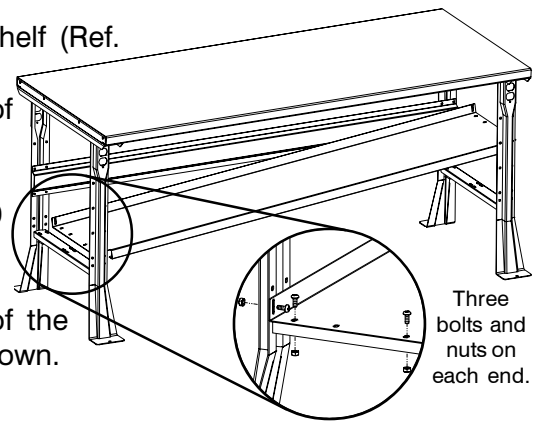

Optional Riser or Electronic Riser

For assembly and installation of a riser or electronic riser, please refer to the instructions which came with the riser kit.